



HIGHLIGHTS

- Full color, D1 resolution (720 x 480)
- Up to 30 frames per second
- H.264 and MJPEG eval codecs pre-installed
- Supports TI and 3rd Party codecs including H.264 BP/MP, MPEG-4/H.263, MPEG-2, and MJPEG
- 10/100 Ethernet TCP/IP compressed video stream
- RTP/RTSP over UDP
- Unicast or Multicast GUI settings
- Ultra-compact form factor
- Pixim's ultra-wide dynamic imaging range (WDR) 102 dB typical / 120 dB Max
- TI DaVinci™ DM6446 Dual-Core DSP with ARM926
- Video Analytics-capable
- Real-Time Embedded Linux
- Decodes to any networked PC running a decoder such as QuickTime or VLC Player
- Browser-based Utility allows configuration of settings and parameters
- 12V DC, 4.5W max
- PoE Functionality Standard
- RoHS compliant
- No blind/buried vias, no via-in-pad
- Available as evaluation unit or production license with fully licensable design

OVERVIEW

Nuvation's IP Camera 'PoE' DM6446 Reference Design is a compact, PoE-enabled implementation of a D1, full color, WDR, IP Camera based on Pixim's Orca chipset and TI DaVinci™ DM6446 Dual-Core DSP with ARM926. The reference design is targeted for high-quality IP Box Cameras which can be taken to production quickly. Derivative products can also be developed from the reference design.

PACKAGES

- **Evaluation Units*** are intended for OEMs interested in evaluating the reference design for production license. Users can plug-and-play the IP Camera PoE right out of the box, and experiment with different sensor and codec settings. Advanced users may experiment with reprogramming the DM6446 with their own custom software builds.
- **Production Licenses*** are intended for full manufacturing and IP control including rights to make derivative products.

*Package details are listed on page 3.

SOFTWARE & DRIVERS

- Runs Montavista Linux 2.6 with TI DaVinci™ board support package by Nuvation
- Encoder firmware application that encodes and streams video in real-time
- *thttpd* lightweight web server runs a browser utility for easy camera configuration
- Driver support for USB, video-input and UART RS-232 communication

EXTERNAL INTERFACES

- Ethernet (RJ-45) with PoE support
- Analog Video (NTSC / PAL)
- USB 2.0 OTG (DM6446 driver default is master for connecting Wi-Fi or Storage)
- Auto-Iris
- Joystick for Pixim settings menu navigation
- Two dip switches (can be SW-enabled)

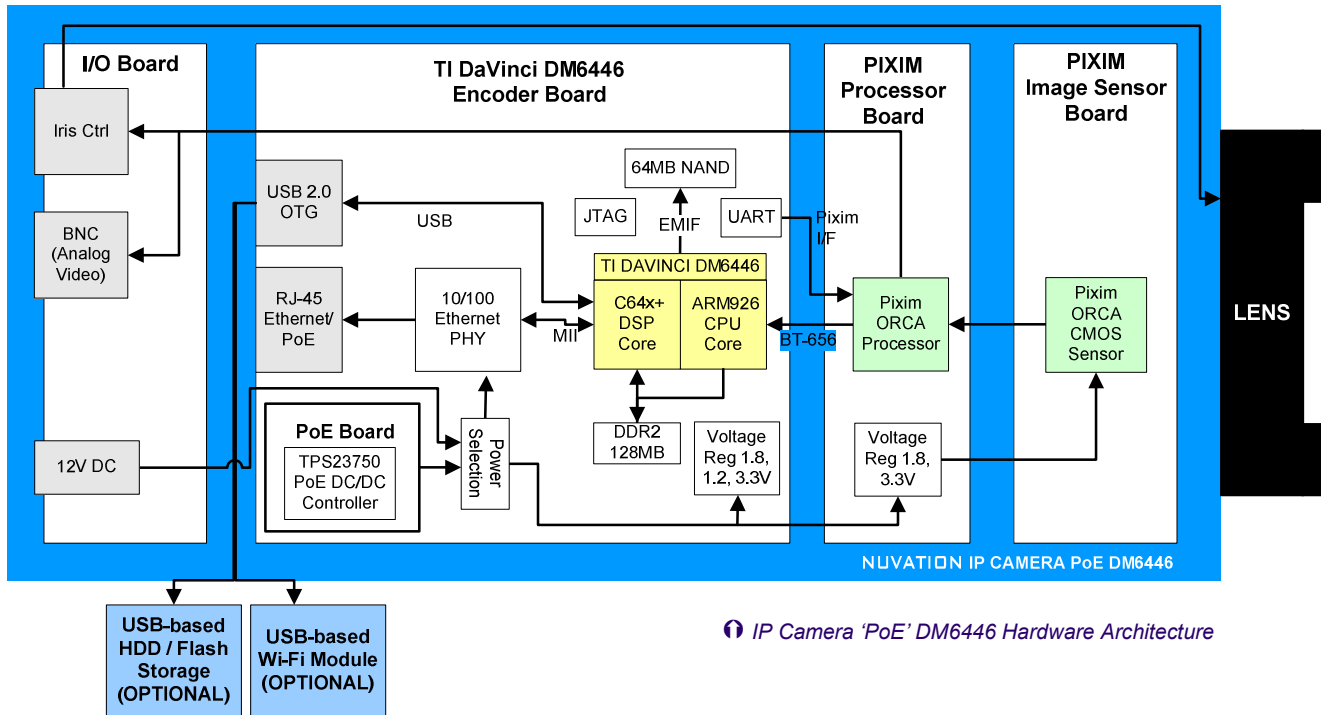

SYSTEM ARCHITECTURE

At the front of the IP camera, behind the lens, sits a Pixim ORCA CMOS sensor and processor, which captures and processes images and sends out BT.656 digital video to a TI DaVinci™ DM6446 processor. The DaVinci™ processor encodes the stream and transmits the compressed video over Ethernet.

Within the DaVinci™, the incoming BT.656 video stream is processed by the Video Processing Front End (VPFE) and sent to the C64+ DSP for encoding. The DSP encodes it with the chosen video codec and passes the data back to the ARM. The ARM then packetizes the stream using the RTP/RTSP protocol and sends it to the Ethernet PHY chip for transmission over the network.

A web server running on the ARM within the DaVinci™ allows users on the network to configure IP Camera settings through a browser utility. Setting changes are sent over the UART interface to the PIXIM processor board using a proprietary protocol.

PIXIM CMOS IMAGING CHIPSET

- Pixim ORCA D1600 or D2500 imaging chipset
- High resolution color for crisp, clear capture
- Progressive image capture - 540 HTVL equivalent
- Wide dynamic range 102 dB typical / 120 dB Max
- Full resolution D1 (NTSC / PAL)
- Full frame-rate up to 30 fps
- Optimum exposure mode presets
- Fully automatic operation (ATW, AGC, BLC, etc.)
- Advanced noise reduction technology improves image quality and reduces bit rate
- Pixim Processor Software features controls such as gamma, white balance, sharpness, even motion detection and digital PTZ.

SYSTEM COMPONENTS

- Pixim Image Sensor Board
 - Pixim D1100 ORCA CMOS sensor
 - WDR NTSC
- Pixim Processor Board
 - Pixim D2500 ORCA processor
 - BT-656 output to encoder board
- TI DaVinci™ DM6446 Encoder Board
 - TI DaVinci™ DM6446 with C64x+ DSP and ARM926E
 - 2 banks of DDR2, 128MB, 32bit x 167MHz
 - 64MB NAND Flash
 - UART Port
 - JTAG Port
 - 10/100 Ethernet MAC routed to Ethernet PHY board
 - USB 2.0 routed to OTG connector on IO board
 - No blind or buried vias, no via-in-pad
- PoE Board
 - Small, horizontal board
 - PoE 802.3af-compliant PD Controller with integrated DC/DC controller
- I/O Board
 - BNC for NTSC/PAL pass-through
 - 12V in
 - Auto-Iris
 - Joystick for accessing full Pixim menu tree
 - Dip switches

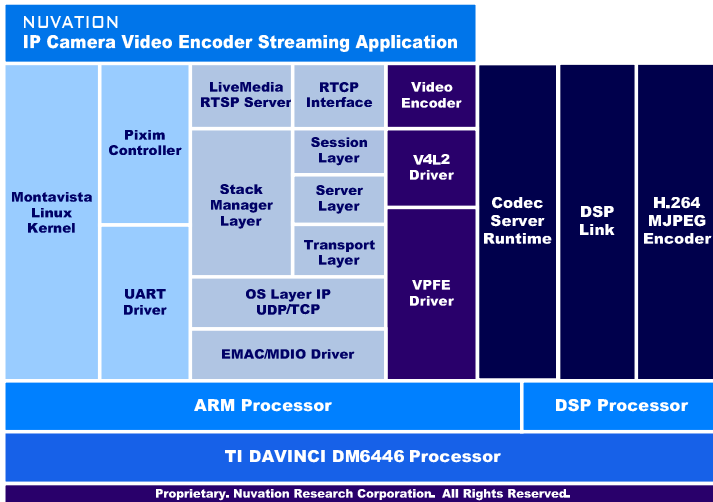

IP Camera Software Architecture

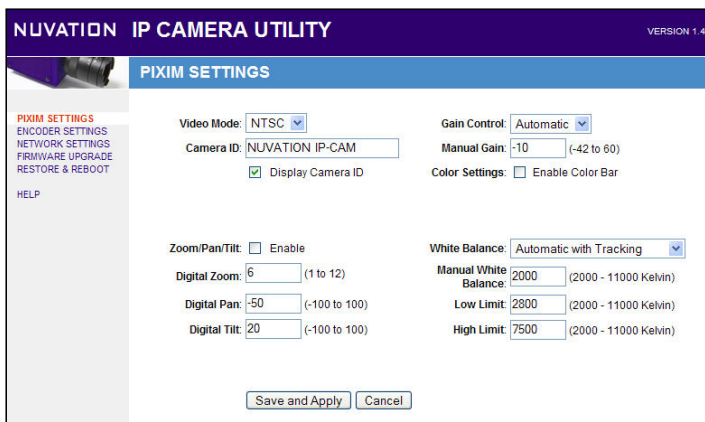

Browser Utility Screen Shot

TI DAVINCI™ DM6446 SOFTWARE OPTIONS

- Pre-programmed TI eXpressDSP Digital Media software:
 - H.264 BP encode (evaluation)
 - MJPEG encode (evaluation)
- TI DaVinci™ DM6446 also supports H.264 MP, MPEG-4/H.263, and MPEG-2 video encoders and a full range of audio encoders from TI and 3rd Parties.
- IP CAM 'PoE' is pre-programmed with embedded Linux 2.6 with real-time extensions, running on a ARM926 co-processor within the DaVinci™
- Video content analytics capable, custom or licensable

DSP SOFTWARE

- The DSP runs the complex algorithms required to encode the raw video into the various video codec formats
- The ARM is responsible for managing the digital video interface, the Pixim sensor and the web server

BROWSER UTILITY

Included browser-based utility enables users to change encoder settings such as H.264/MJPEG, frame rate, bit rate, white balance, gain control, camera ID, update camera software, and change IP and MAC addresses. Served from the ARM within the DaVinci™, the following groups of parameters can be configured:

- PIXIM Settings
- Encoder Settings
- Network Settings
- Firmware Upgrade
- Restore & Reboot

EVALUATION UNIT PACKAGE

The evaluation unit package includes:

- IP Camera pre-programmed with TI's H.264BP encoder and MJPEG codec
- Camera lens
- Ethernet cable and DC power adapter
- Nuvation-optimized Linux Board Support Package
- IP Camera Utility (Browser-based GUI)
- Quick Start Guide (QSG)
- Technical Reference Manual (TRM)

PRODUCTION LICENSE PACKAGE

Licensees receive entire design source code package:

- Design schematics
- Bills of materials
- Layout databases
- Linux source code
- Hardware and software specification documents
- Enclosure CAD mechanicals
- Manufacturing instructions

DIMENSIONS

- L: 4.25" (108mm), H: 1.7" (43mm), W: 1.8" (47mm)

CONTACT

EMAIL IP@NUVATION.COM
 WEB WWW.NUVATION.COM
 TEL +1.408.228.5580
 FAX +1.408.228.5590